

ROHS

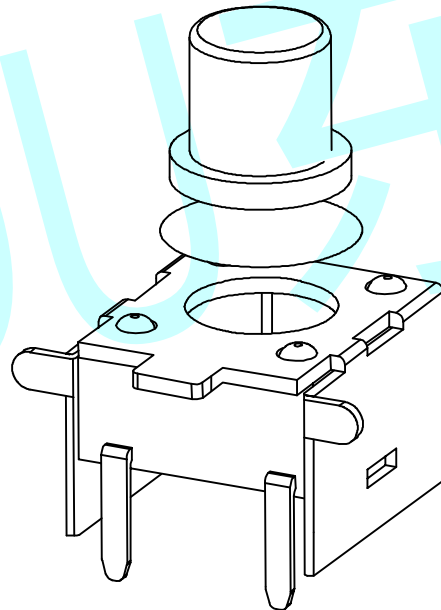

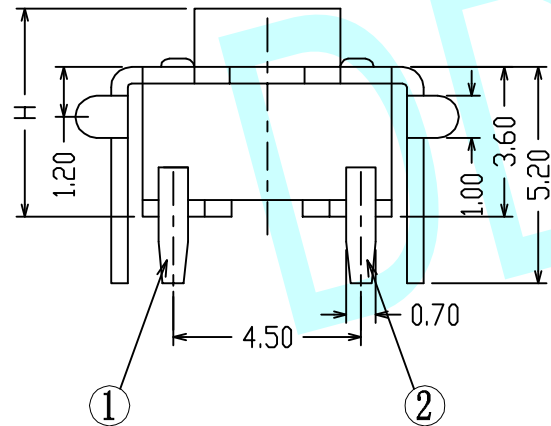
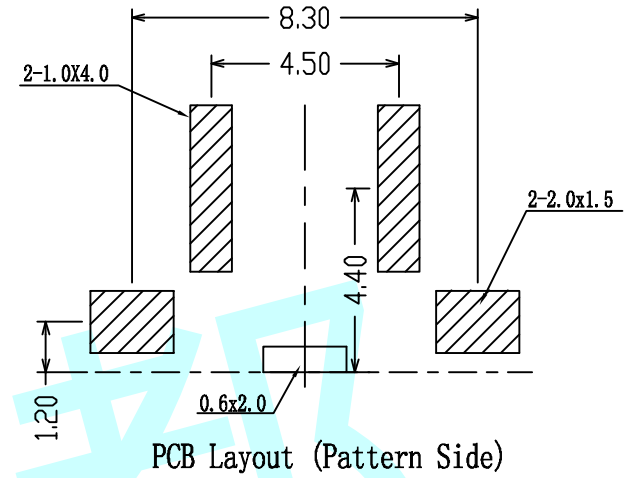
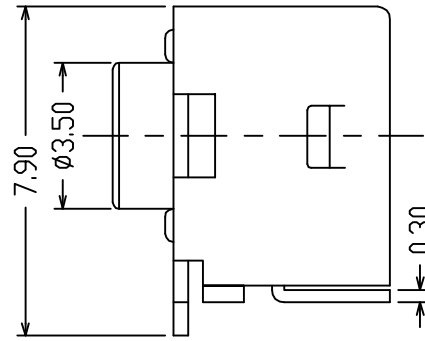
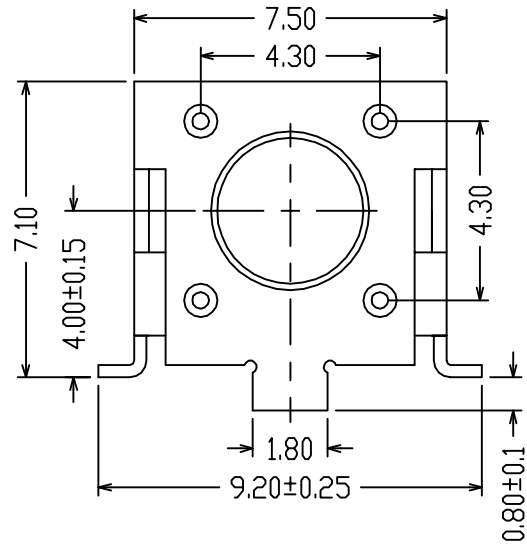
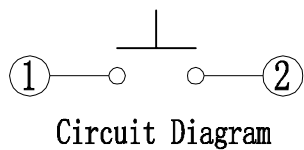

NOTES:

1. Rate voltage. current: 50mA DC 12V
2. Contact resistance: $\leq 100m\Omega$
3. Travel: $0.25 \pm 0.10mm$
4. Insulated resistance: $\geq 100M\Omega$
5. Dielectric strength: $\geq 250V AC/1min$
6. Endurance: 100, 000 cycles



H	4.3	4.5	5.0	5.5	6.0	6.5	7.0	7.5	8.0
Stergth		130±30			180±30		250±30		

APPROVALS		DATE		http://www.dongdudz.com			 东都电子 DONGDU ELECTRONICS	
DRAW:	ZRD	2017-12-6		TOLERANCE:		ANGLE:		
CHECKED:	***	****		30 \geq	± 0.30	$\pm 2^\circ$		
APPOVALS:	***	****		10 \sim 30	± 0.20			
				5 \sim 10	± 0.15			
				≤ 5	± 0.10	MODEL:	TACT SWITCHES	
						PART NO:	DDU-1196	
						UNIT :mm	SCALE: 1:1	
						REV:	A	PAGE: 1/1