

ROHS

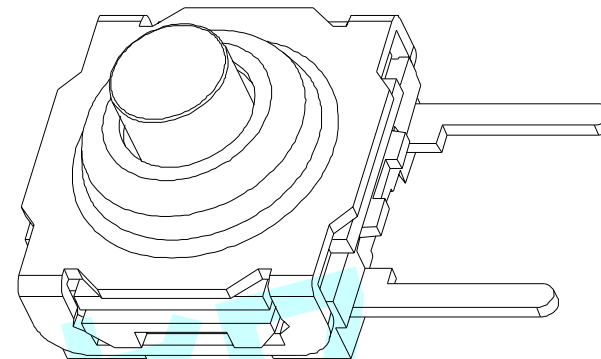

Circuit Diagram

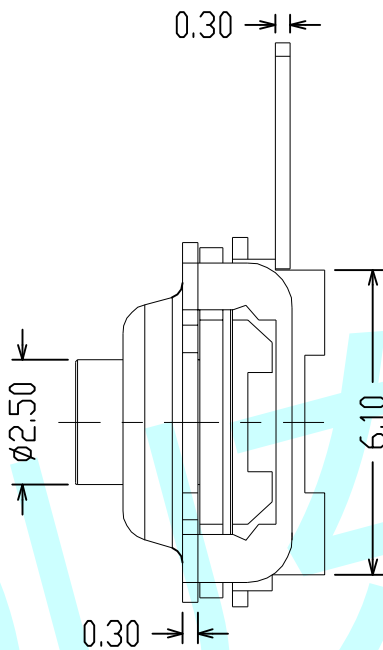

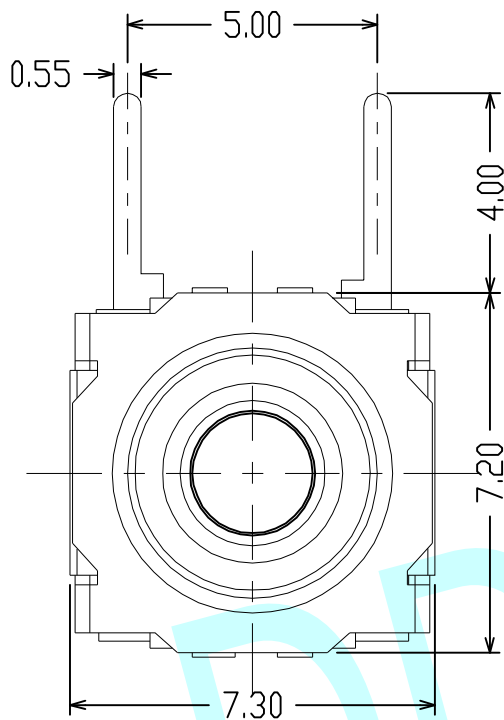
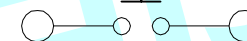

NOTES :

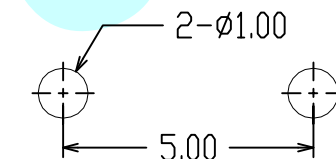
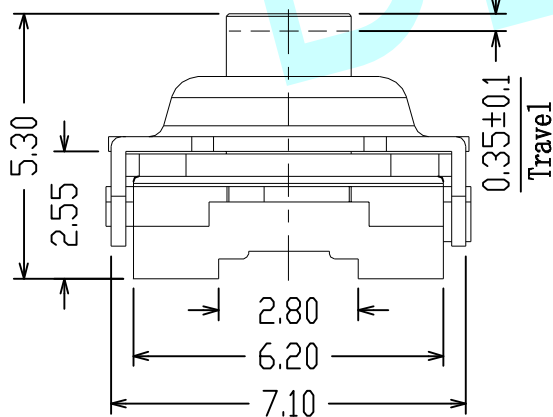
1. Rating :DC 12V 50mA.
2. Contact resistance: $\leq 100m\Omega$
3. Insulation resistance: $\geq 100M\Omega$
4. Travel: $0.35 \pm 0.10mm$
5. Waterproof grade: IP66



PCB Layout (Pattern Side)

APPROVALS		DATE	http://www.dongdudz.com		 东都电子 DONGDU ELECTRONICS	
DRAW:	ZRD	2017-12-6	TOLERANCE:	ANGLE:		
CHECKED:	***	****	30°	±0.30		±2°
APPOVALS:	***	****	10°30'	±0.20		
			5°10'	±0.15		
			≤5	±0.10	MODEL: TACT SWITCHES PART NO: DDU-1125DF UNIT :mm SCALE: 1:1  REV: A PAGE: 1/1	