

ROHS

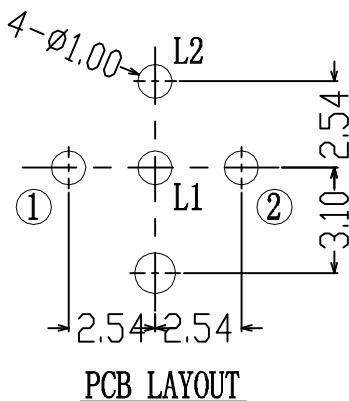

NOTES:

- A. Electrical characteristics
1. Rating: 50mA 12V DC
  2. Contact resistance: 50mΩ max (Initial)
  3. Insulation resistance: 100MΩ min (at 250V DC)
  4. Dielectric strength: AC 250V (50~60Hz) for 1 minute
  5. LED operating current: 20mA max
- B. Mechanical characteristics:
1. Operating force: 250 ± 80gf
  2. Travel: 0.25 ± 0.1mm
  3. Static load: 3Kg/60 sec
  4. Operating life: 100,000 cycles min
  5. Operating temperature: -20°C ~ +70°C

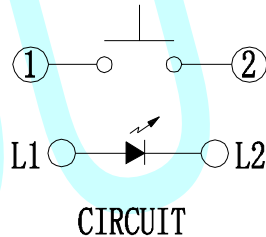
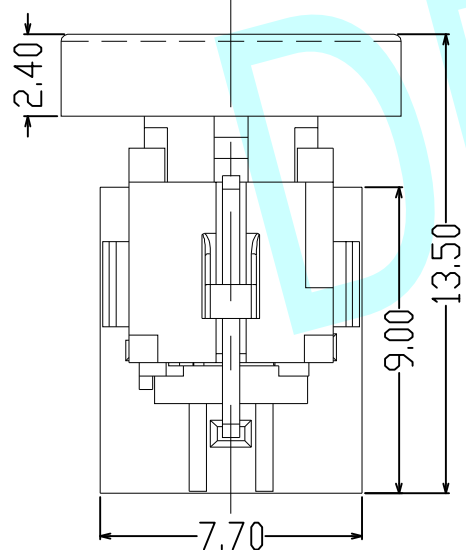
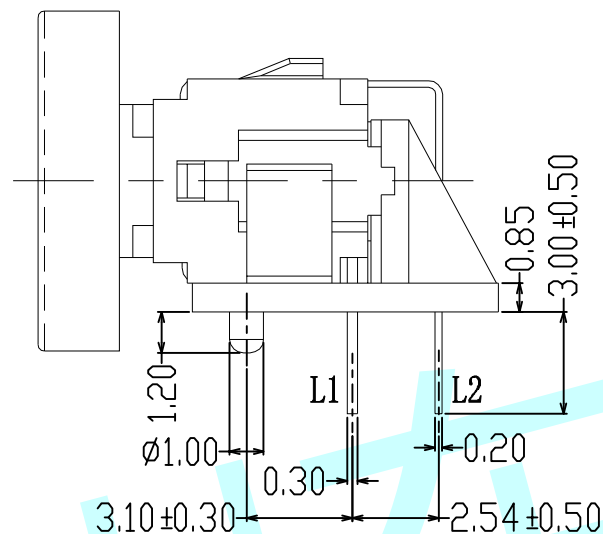
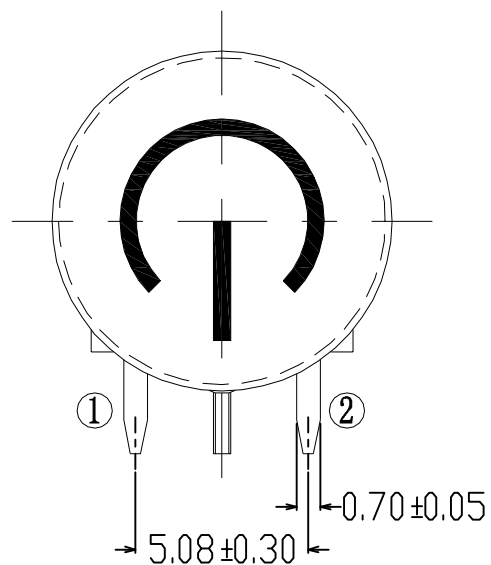
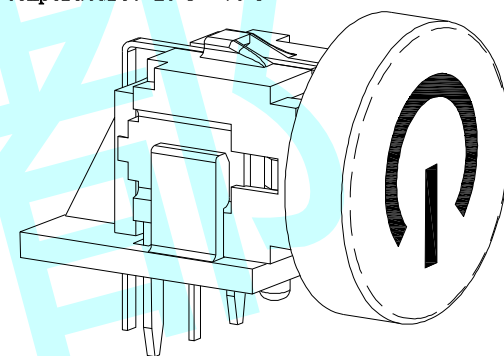

LED COCLOR									
1	2	3	4	5	6	23	13	12	52
Red	Yellow	Green	Blue	White	Pure green	Yellow Green	Red Green	Red Yellow	White Yellow
NO.	PART NAME		MATERIAL			Q' TY	FINISHING		
1	COVER		ABS			1	SILVER		
2	BUTTON		PA66			1	NATURAL		
3	CONTACT		STAINLESS STEEL METAL			1			
4	TERMINAL		H65 (C2680)			2	Ag PLATED		
5	LED		GaASP/Gap			1			
6	BASE		PA66			1	BLACK		
7	HOLDER		PA66			1	BLACK		

APPROVALS		DATE		http://www.dongdudz.com	
DRAW:	ZRD	2017-12-6	TOLERANCE:	ANGLE:	
CHECKED:	***	****	30°	±0.30	±2°
APPOVALS:	***	****	10°30'	±0.20	
			5°10'	±0.15	
			≤5	±0.10	

**东都电子**

DONGDU ELECTRONICS

MODEL:	LED Tact Switch
PART NO:	DDU-1561
UNIT :mm	SCALE: 1:1
REV:	A