

ROHS

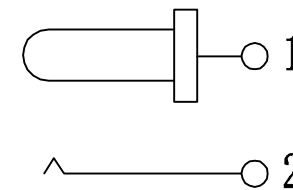

CIRCUIT DIAGRAM

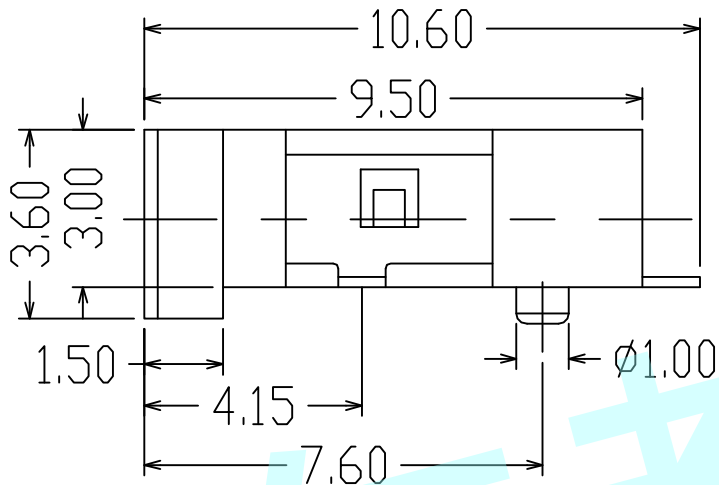

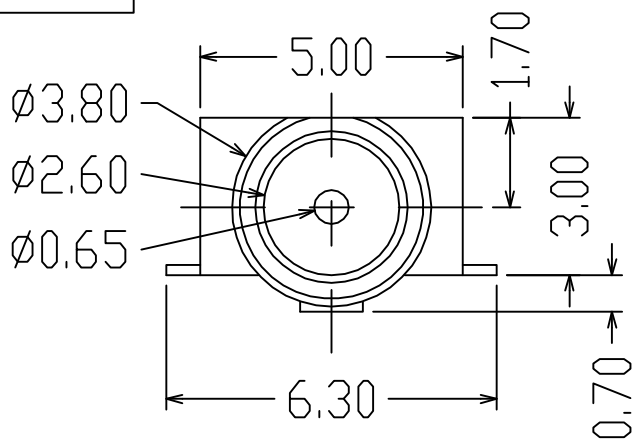
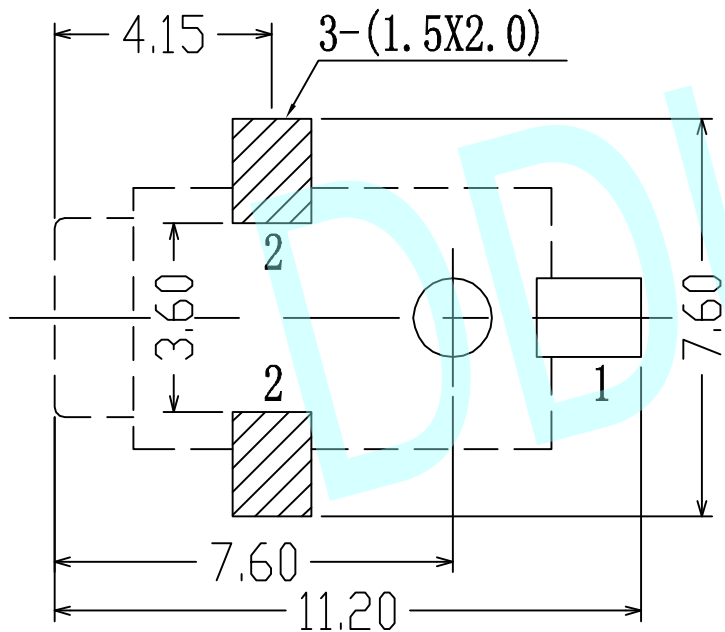

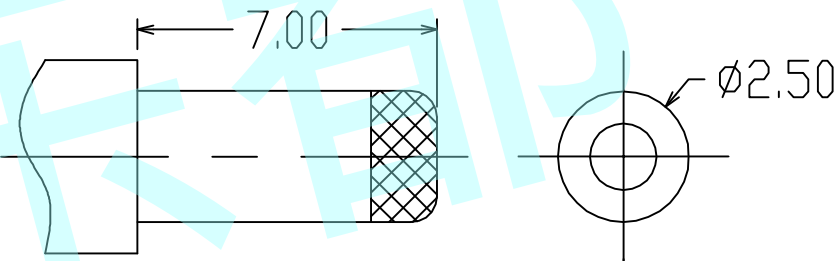
PCB Layout Top View



DC MATE PLUG

NOTES:

1. Rating: 0.5A 30V DC
2. Contact Resistance: 100mΩ Max
3. Operating temperature: -20°C ~ 70°C
4. Operating force: 3-20N
5. Operating Life: 5,000 cycles

APPROVALS		DATE	http://www.dongdudz.com		 ® 东都电子 DONGDU ELECTRONICS
DRAW:	ZRD	2017-12-6	TOLERANCE:	ANGLE:	
CHECKED:	***	***	30°	±0.30	
APPOVALS:	***	***	10°30'	±0.20	
			5°10'	±0.15	
			≤5	±0.10	MODEL: DC POWER JACK PART NO: DC-061S UNIT :mm SCALE:1:1  REV: A PAGE:1/1