

ROHS

机壳面板

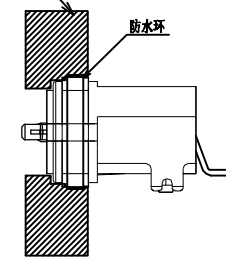

前后组装方式

NOTES:

A. Electrical:

1. Current rating:
VBUS and GND contacts rated at 1.25A
Paralleled for a total of 3A
2. Initial contact resistance: 40mΩ
3. Dielectric withstanding voltage: AC 30V min

B. Material:

1. Housing: LCP
2. Contact: C2680, T=0.20mm
3. Shell: Zinc alloy

C. Mechanical characteristics:

1. Mating force: 5~20N
2. Unmating force: 8~20N (Initial)
6~20N (After 10000 cycles)
3. Frequency: 200±50 cycles/hour 10000 cycles
4. Operating temperature: -40°C~+80°C

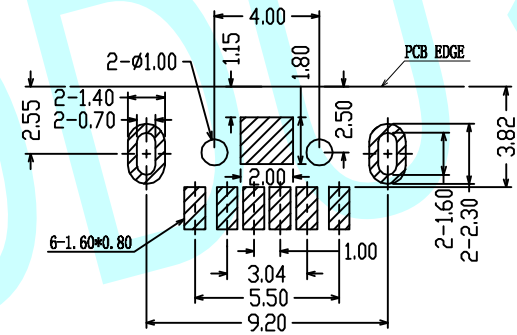
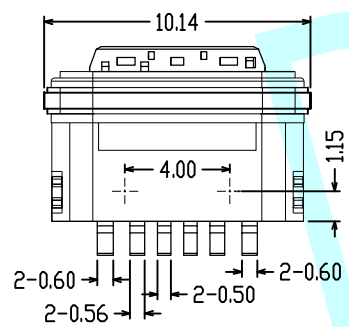
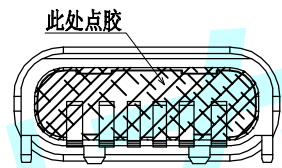
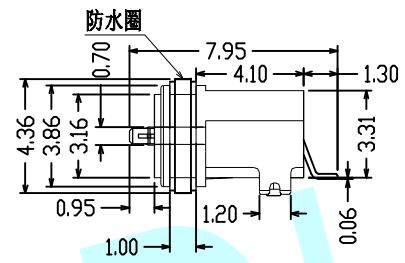
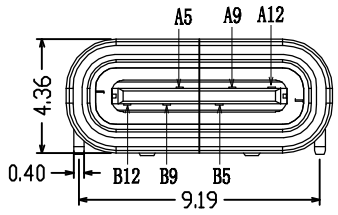
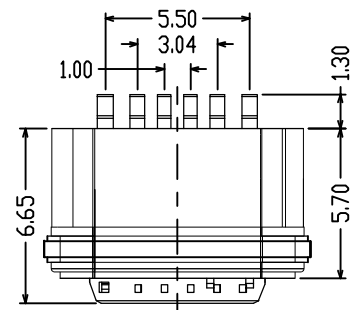

D. Waterproof: IP-X7



RECOMMENDED PCB LAYOUT
TOLERANCE UNSPECIFIED ±0.05mm

Pin	Signal Name
B12	GND
B9	VBUS
B5	CC2
A5	CC1
A9	VBUS
A12	GND

NO.	DESCRIPTION	MATERIAL	REMARKS	QTY
4	防水圈	硅胶	GREEN	1PCS
3	SHELL	Zinc Alloy.	Die casting	1PCS
2	CONTACT	BRASS	Au Plated	1SET
1	MD	HIGH TEMPERATURE PLASTIC	BLACK	1PCS

APPROVALS		DATE	http://www.dongdudz.com		 东都电子 DONGDU ELECTRONICS
DRAW:	ZRD	2017-12-6	TOLERANCE:	ANGLE:	
CHECKED:	***	***	30≥	±0.30	
APPOVALS:	***	***	10~30	±0.20	
			5~10	±0.15	
			≤5	±0.10	
MODEL:	USB CONNECTOR				
PART NO:	TYPE. C-6P-IPX7				
UNIT :mm	SCALE: 1:1				
REV:	A	PAGE: 1/1			