

# ROHS

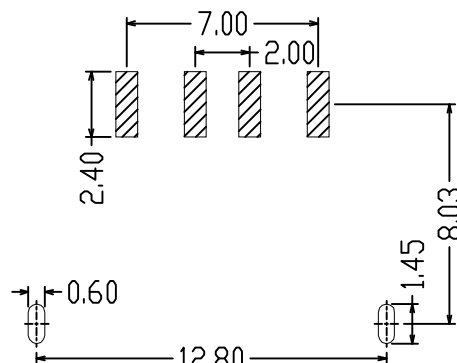
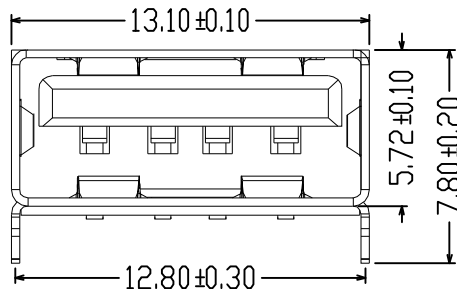

RECOMMENDED PCB LAYOUT (COMPONENT SIDE)  
PCB T=1.60mm (TOLERANCE:±0.05)

**NOTE:**

**A. 电气性能:**

1. 额定电流: 2A
2. 接触阻抗: 30mΩ MAX
3. 绝缘阻抗: 100V DC/100MΩ MIN
4. 耐电压: 500V AC/1mA MAX

**B. 机械性能:**

1. 插入力: 35N MAX
2. 拔出力: 10N MIN
3. 使用寿命: 3000 cycles

**C. 材料:**

1. 塑胶: LCP+30%G.F BLACK UL94V-0
2. 端子: C2680 T=0.25mm
3. 外壳: SPCC T=0.30mm

**D. 电镀:**

1. 端子: 接触点镀金10μ" MIN  
PIN 脚焊接区域镀亮锡100μ" MIN
2. 外壳: 镀镍80μ" MIN (盐雾24H)

**E. 电镀品需做粘锡测试: 粘锡面积达到95%以上**

**F. SMT回流焊 (峰值260℃±5℃) 不能起泡, 熔胶, 变色不良 (变形在公差范围以内)**

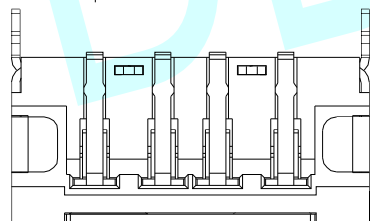
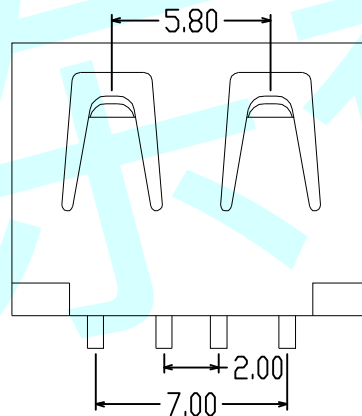
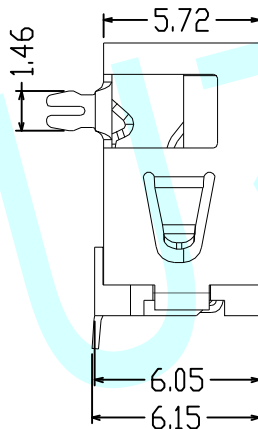
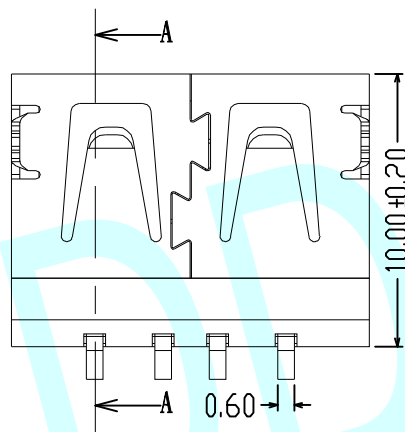
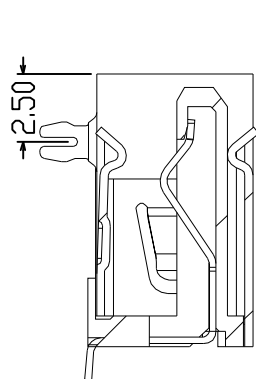

**G. 工作温度: -55℃~+85℃**

**H. 盐雾测试: 通过24H在浓度为5±1%盐水的盐雾测试无生锈现象**



APPROVALS		DATE	http://www.dongdudz.com	
DRAW:	ZRD	2017-12-6	TOLERANCE:	ANGLE:
CHECKED:	***	***	30°	±0.30
APPOVALS:	***	***	10°30'	±0.20
			5°10'	±0.15
			≤5	±0.10

 <b>® 东都电子</b> DONGDU ELECTRONICS		MODEL:	USB CONNECTOR	
		PART NO:	USB-AF-90D-8	
UNIT :mm	SCALE:1:1			
REV:	A			