

**ROHS**

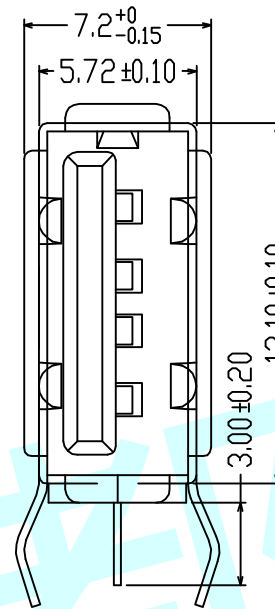
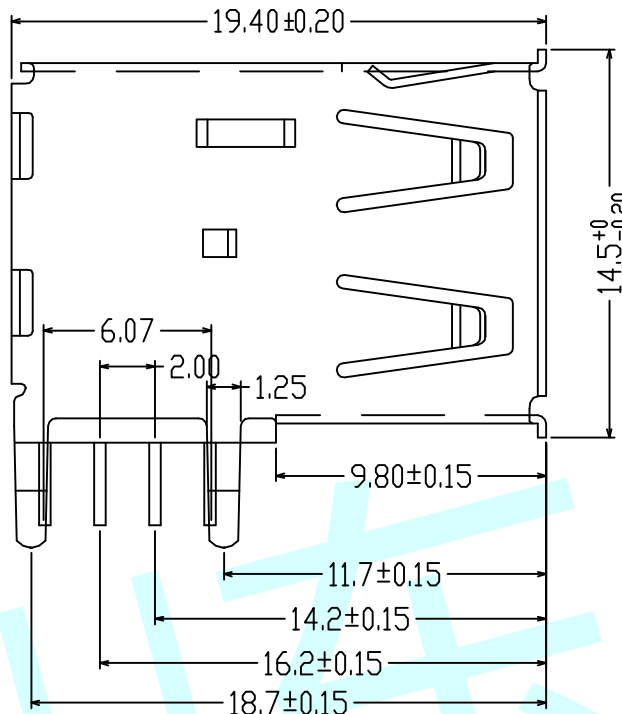
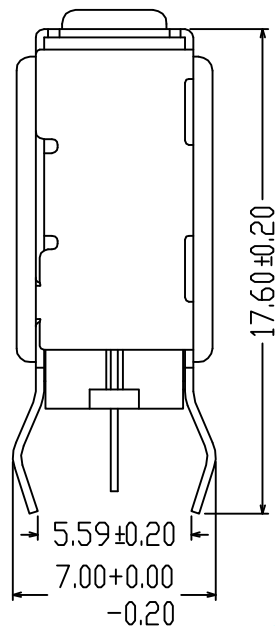

**NOTES:**

**1. MATERIAL SPECIFICATION**

- 1) INSULATION MATERIAL THERMOPLASTIC.
- 2) SHELL: COPPER ALLOY/SPCC, T: 0.30mm  
PLATING: NICKEL
- 3) TERMINAL: COPPER ALLOY, T: 0.25mm  
PLATING: GOLD/TIN PLATED.

**2. ELECTRICAL CHARACTERISTIC:**

- 1) INSULATION RESISTANCE: 10000Ω MIN.
- 2) CONTACT RESISTANCE: 30mΩ MAX.
- 3) WITHSTANDING VOLTAGE: 500V AC.

**3. MECHANICAL CHARACTERISTICS:**

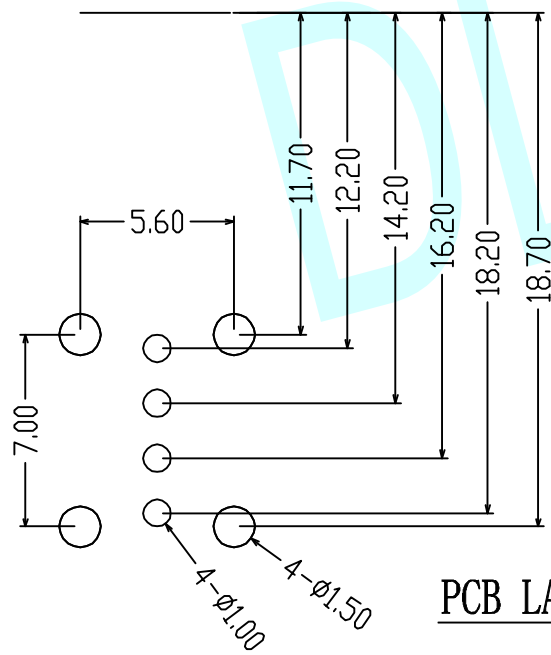

- 1) INSERTION FORCE: 3.57Kgf MAX.
- 2) EXTRACTION FORCE: 1.02Kgf MIN.

**ORDERING INFORMATION**

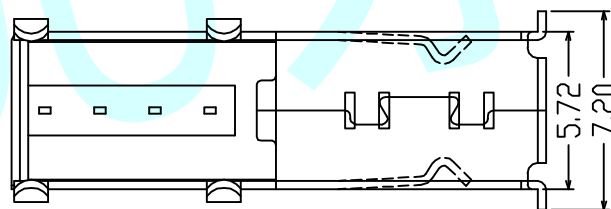

**PCB LAYOUT**



APPROVALS		DATE	http://www.dongdudz.com	
DRAW:	ZRD	2017-12-6	TOLERANCE:	ANGLE:
CHECKED:	***	***	30≥ ±0.30	±2°
APPOVALS:	***	***	10°30 ±0.20	
			5°10 ±0.15	
			≤5 ±0.10	
			 <b>® 东都电子</b> DONGDU ELECTRONICS	
MODEL:		USB CONNECTOR		
PART NO:		USB-90D-01		
UNIT :mm	SCALE: 1:1			
REV:	A	PAGE: 1/1		