

ROHS

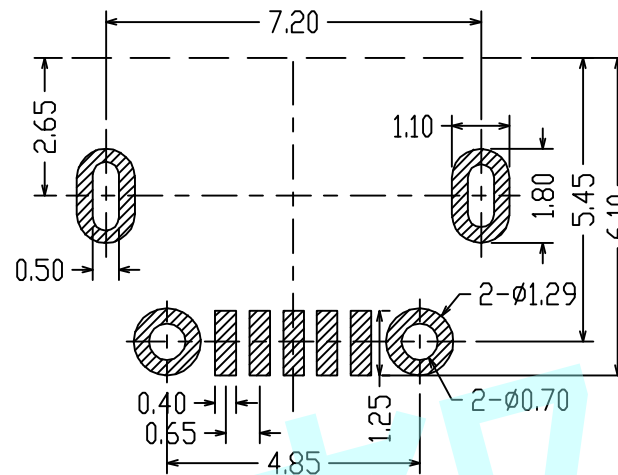

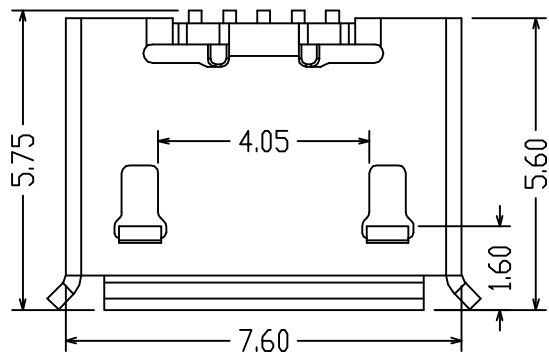

Recommended PCB Layout

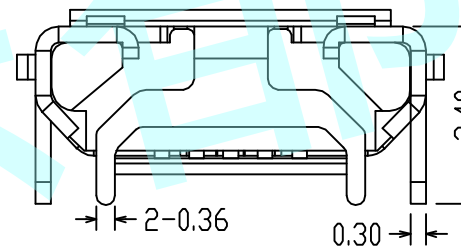
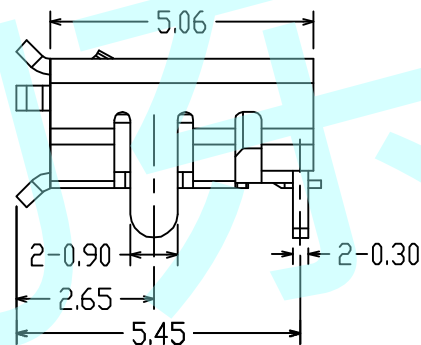
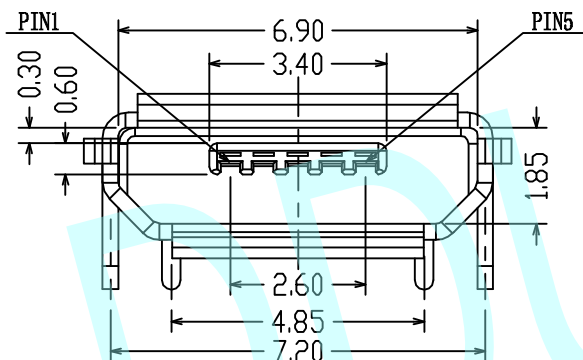

NOTES:

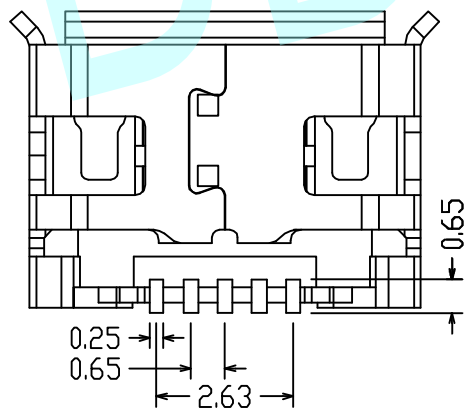
1. Rating:DC 30V 1A
2. Mechanical Life:10,000 Cycles



APPROVALS		DATE	<a href="http://www.dongdudz.com">http://www.dongdudz.com</a>		 <b>® 东都电子</b> DONGDU ELECTRONICS
DRAW:	ZRD	2017-12-6	TOLERANCE:	ANGLE:	
CHECKED:	***	***	30°	±0.30	±2°
APPOVALS:	***	***	10°30'	±0.20	
			5°10'	±0.15	
			≤5	±0.10	
MODEL:	USB CONNECTOR		UNIT :mm	SCALE:1:1	
PART NO:	MICRO USB-M-10		REV:	A	PAGE:1/1