

# ROHS

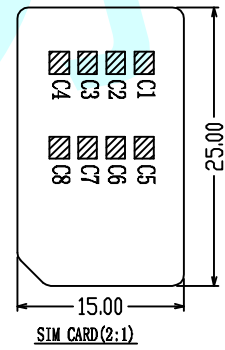
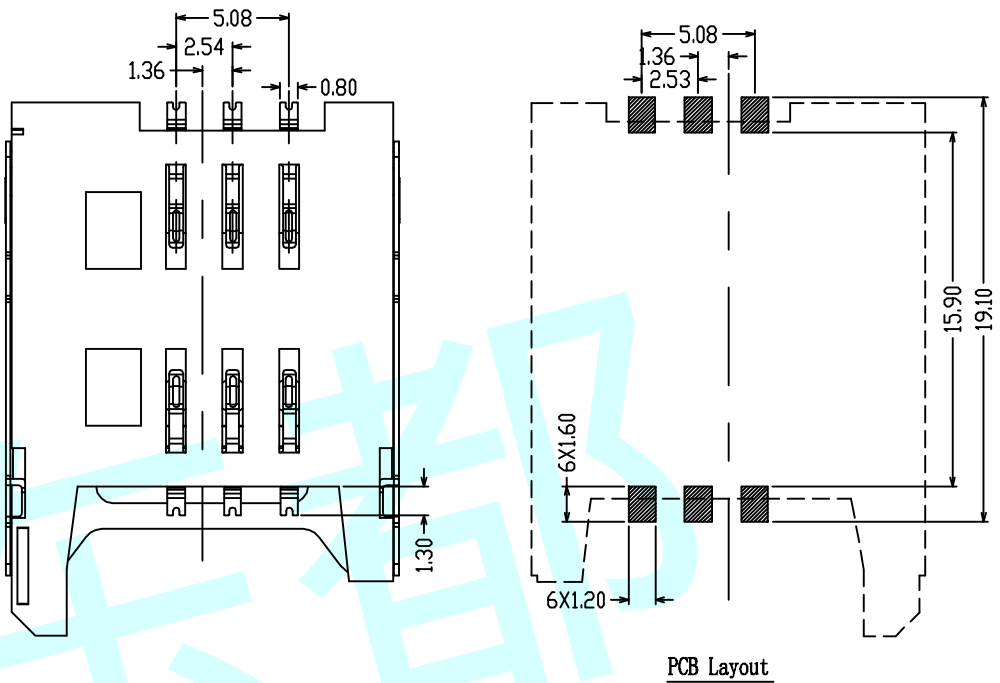
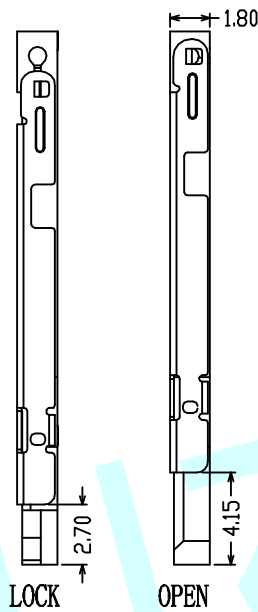
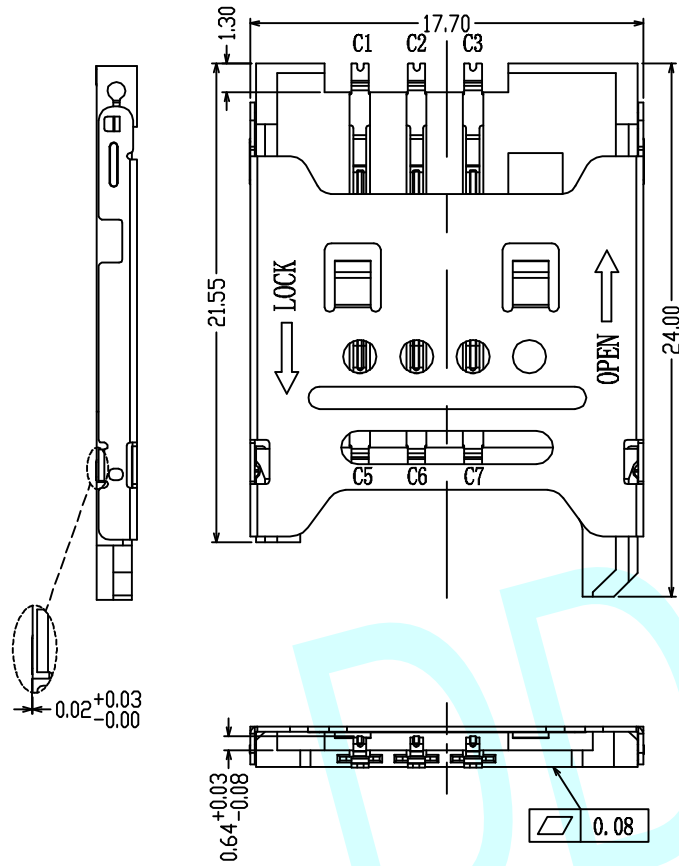

**NOTES:**

1. Current Rating :1A
2. Voltage Rating:12V DC
3. Dielectric Strength:500V AC RMS For 1Minute
4. Contact Resistance:30mΩ MAX
5. Insulator Resistance:500MΩmin, At 250V DC
6. Mating Unmating Cycles; 5000 Cycles

|           |           |                                     |                         |        |
|-----------|-----------|-------------------------------------|-------------------------|--------|
| APPROVALS |           | DATE                                | http://www.dongdudz.com |        |
| DRAW:     | ZRD       | 2017-12-6                           | TOLERANCE:              | ANGLE: |
| CHECKED:  | ***       | ****                                | 30° ≥ ±0.30             | ±2°    |
| APPOVALS: | ***       | ****                                | 10°30 ±0.20             |        |
|           |           |                                     | 5°10 ±0.15              |        |
|           |           |                                     | ≤5 ±0.10                |        |
|           |           | <b>® 东都电子</b><br>DONGDU ELECTRONICS |                         |        |
| MODL:     | CASSETTE  |                                     |                         |        |
| PART NO:  | SIM-0008  |                                     |                         |        |
| UNIT :mm  | SCALE:1:1 |                                     |                         |        |
| REV:      | A         | PAGE:1/1                            |                         |        |