

ROHS

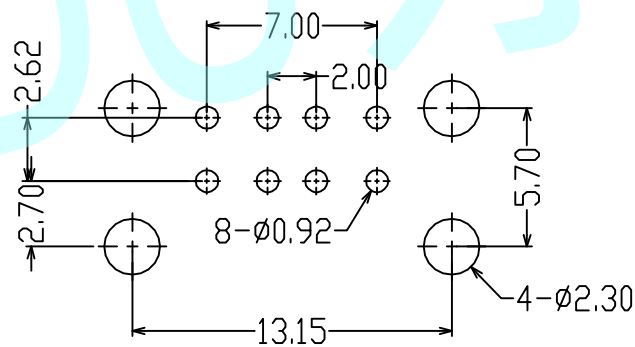
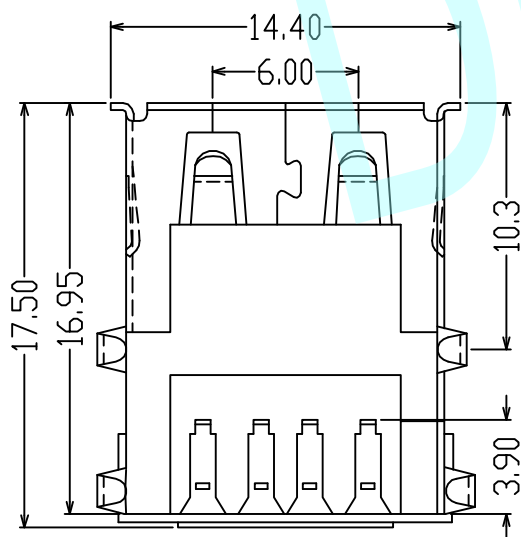
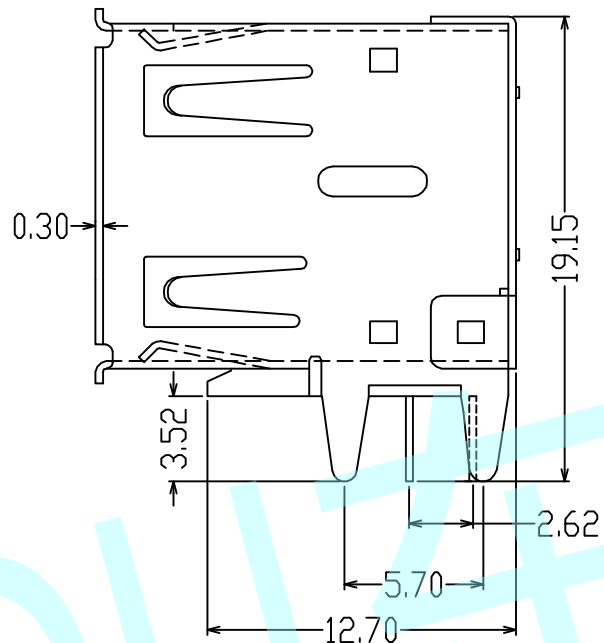
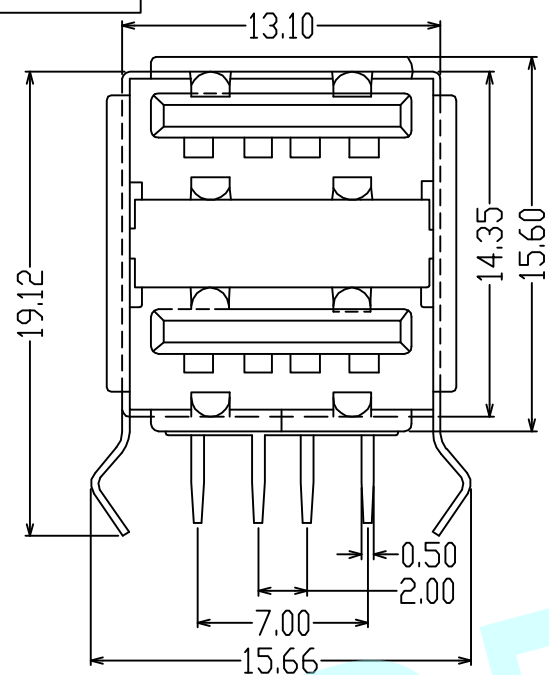

PCB Layout

NOTE:

1. Electrical properties:

- a. Contact impedance: 30mΩ (min)
- b. Insulation impedance: 1000MΩ (min)
- c. High pressure resistance: 500V AC 1 Minute

2. Material Science:



- a. Rubber core: PBT
- b. Terminal: Brass C2680
- c. Shell: Brass C2680/SPCC

3. Electroplate:

- a. Terminal: Contact area gold plating 1u"
- b. Tinning of welding area: 100~200u"

4. Shell:

- a. All area nickel plating: 50~80u"
- b. Black glue iron case, terminal is plated with bright tin, salt spray is over 12H
- c. White glue iron case, terminal plated with bright tin, salt mist passing 12H
- d. Black rubber copper case, terminal plated with bright tin
- e. White rubber copper case, terminal plated with bright tin
- f. Black rubber iron case, terminal coated with tin, salt mist 12H

APPROVALS		DATE	http://www.dongdudz.com	
DRAW:	ZRD	2017-12-6	TOLERANCE:	ANGLE:
CHECKED:	***	***	30≥ ±0.30	±2°
APPOVALS:	***	***	10~30 ±0.20	
			5~10 ±0.15	
			≤5 ±0.10	
		 ® 东都电子 DONGDU ELECTRONICS		
MODEL:	USB CONNECTOR			
PART NO:	USB-90D-02 (有卷边)			
UNIT :mm	SCALE:1:1			
REV:	A	PAGE:1/1		