

# ROHS

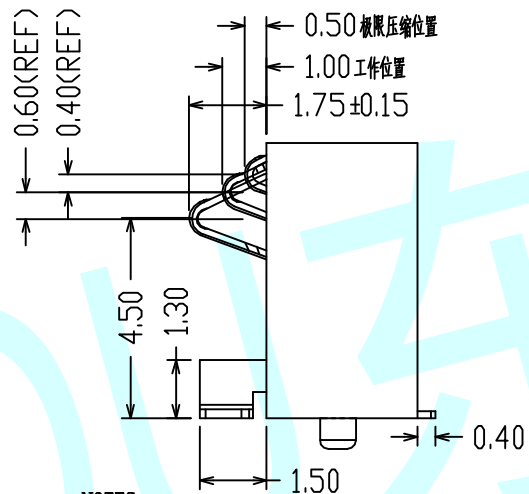

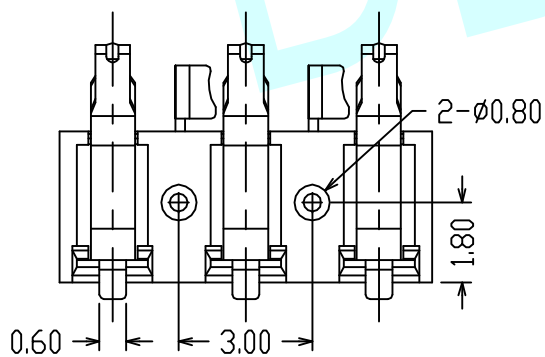
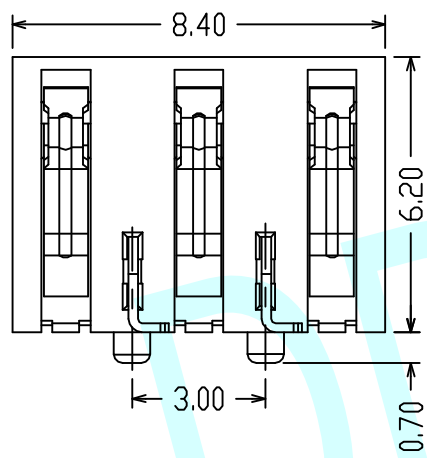
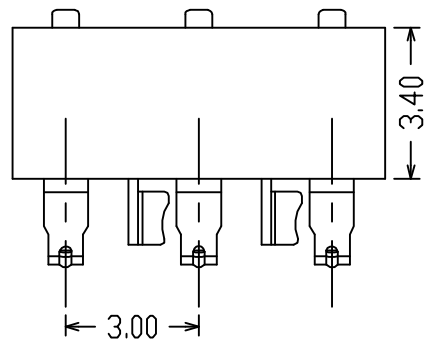
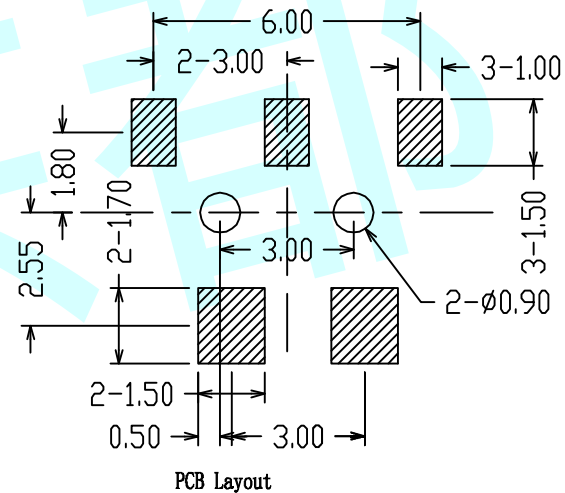
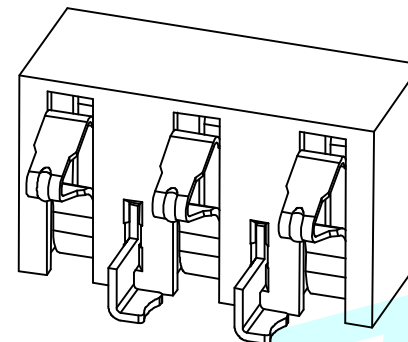

**NOTES:**

1. Voltage Rating :250V AC Min
2. Current Rating :2.0A Min
3. Dielectric Strength :500V AC For 1Minute
4. Insulation Resistance :1000MΩ Min
5. Contact Resistance :30mΩ Max
6. Operation Temperature :-55℃~+125℃
7. Product Withstanding Reflow Soldering :260℃ For 15S
8. Durability :5000 Cycles
9. Normal Force At Working Position :80g Min



PCB Layout

APPROVALS		DATE	http://www.dongdudz.com			
DRAW:	ZRD	2017-12-6	TOLERANCE:	ANGLE:		
CHECKED:	***	****	30≥	±0.30		
APPOVALS:	***	****	10~30	±0.20		
			5~10	±0.15		
			≤5	±0.10		
			±2°			
		 <b>® 东都电子</b> DONGDU ELECTRONICS				
		MODEL:			BATTERY	
		PART NO:			BH-04-3PD	
		UNIT :mm	SCALE:1:1			
		REV:	A	PAGE:1/1		