

ROHS

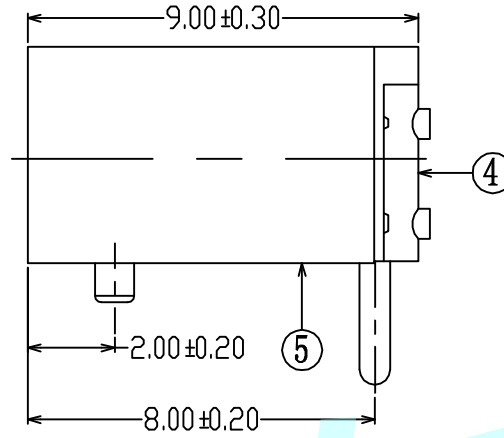

NOTES:

1. Insertion force: 5~30N(0.3~3.0kgf)
2. Pull out force: 5~30N(0.3~3.0kgf)
3. Contact resistance: $\leq 50m\Omega$
4. Insulation resistance: $\geq 100M\Omega$ DC 50V
5. Withstand voltage: AC 500V 1min
6. Life: 5000 cycles, 10~20 cycles/min
7. Rated load: DC 30V 1A
8. Service temperature: $-25^{\circ}C \sim 85^{\circ}C$

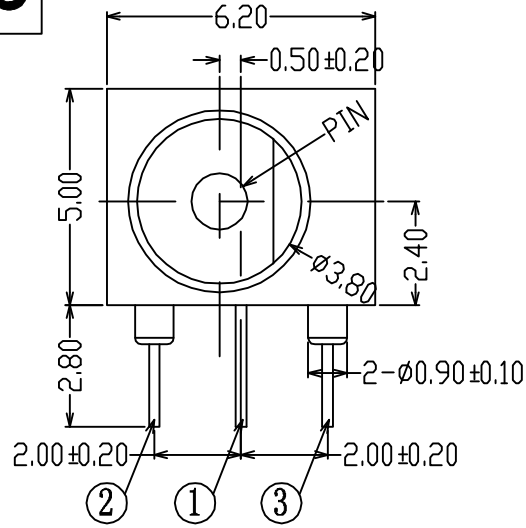
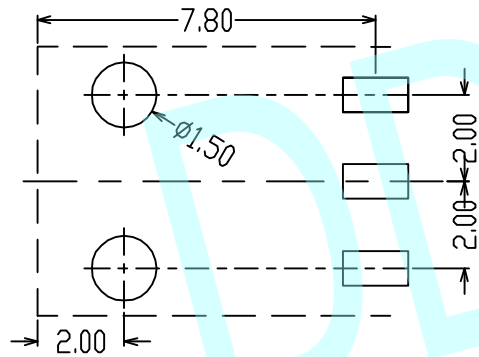

PCB LAYOUT

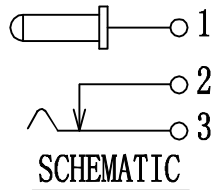

SCHEMATIC

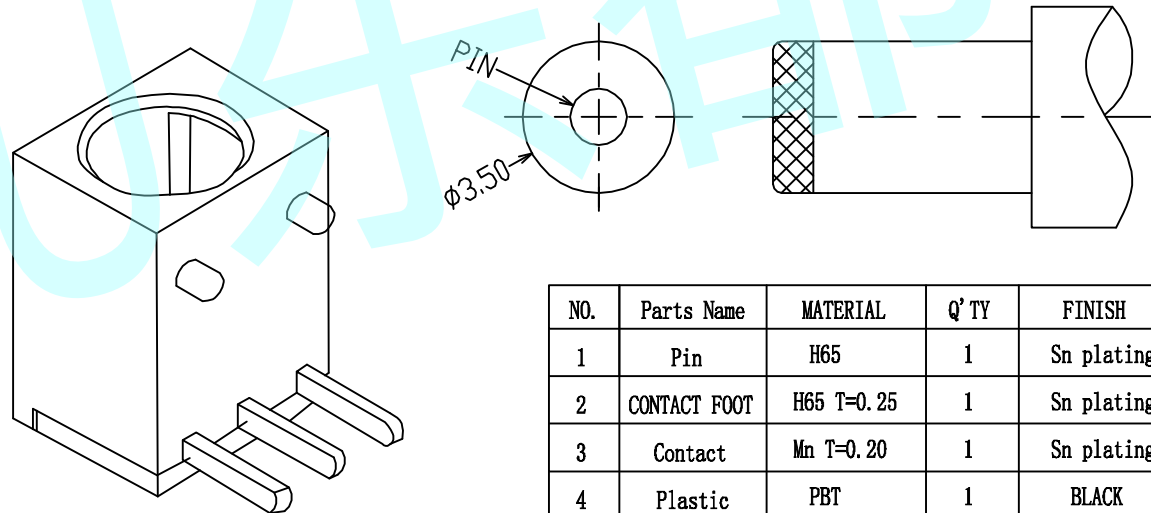

NO.	Parts Name	MATERIAL	Q' TY	FINISH	REMARK
1	Pin	H65	1	Sn plating	
2	CONTACT FOOT	H65 T=0.25	1	Sn plating	
3	Contact	Mn T=0.20	1	Sn plating	
4	Plastic	PBT	1	BLACK	
5	COVER	PBT	1	BLACK	

APPROVALS		DATE	http://www.dongdudz.com	
DRAW:	ZRD	2017-12-6	TOLERANCE:	ANGLE:
CHECKED:	***	***	30 \geq	±2°
APPOVALS:	***	***	10~30	
			5~10	
			≤5	

东都电子
 DONGDU ELECTRONICS

MODEL:	DC POWER JACK
PART NO:	DC-003
UNIT :mm	SCALE:1:1
REV:	A

PIN	∅1.00	∅1.30
-----	-------	-------