

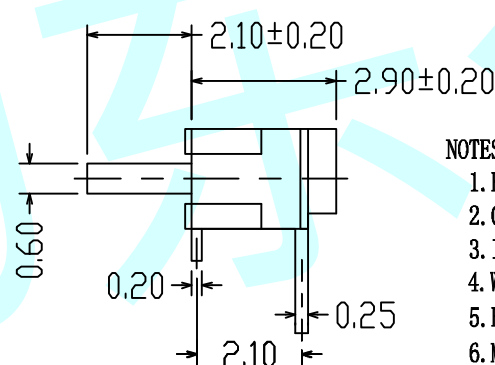

**ROHS**

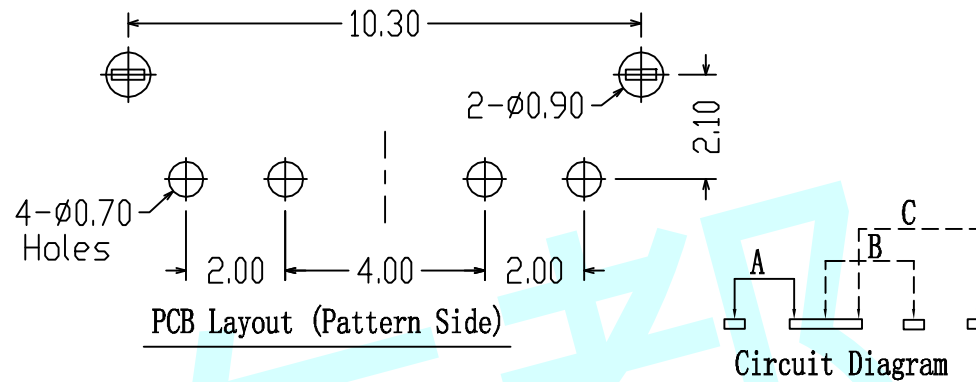
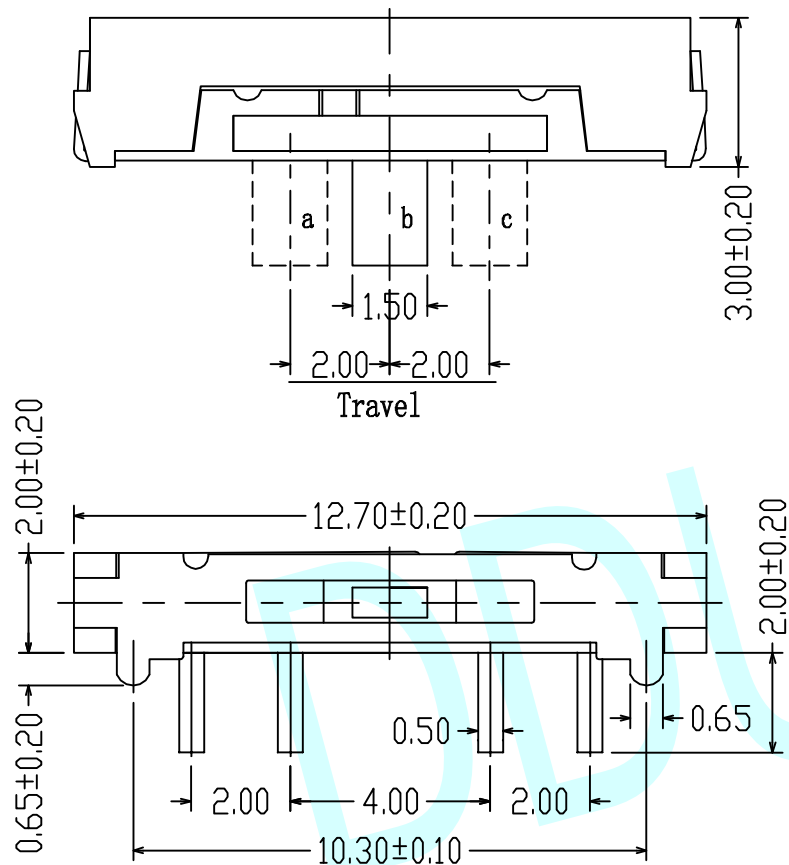

- NOTES:**
1. Rating: DC 4V 300mA
  2. Contact Resistance: ≤50mΩ
  3. Insulation Resistance: ≥100MΩ
  4. Withstand voltage: AC 500V 1 Minute
  5. Electrical Life: 10,000 Cycles above (Load)
  6. Mechanical Life: 10,000 Cycles (NO Load)
  7. Operating force range: 200gf±100gf
  8. Operating temperature range: -25°C+80°C
  9. Ambient humidity used: ≤85%RH
  10. Solder ability: 245°C±5°C, 3S±0.5S
  11. Withstand Soldering temperature: 260°C±5°C, 3S±1S

APPROVALS		DATE	http://www.dongdudz.com	
DRAW:	ZRD	2017-12-6	TOLERANCE:	ANGLE:
CHECKED:	***	***	30° ≥ ±0.30	±2°
APPOVALS:	***	***	10°~30 ±0.20	
			5°~10 ±0.15	
			≤5 ±0.10	
			 <b>® 东都电子</b> DONGDU ELECTRONICS	
MODEL:		TOGGLE SWITCHES		
PART NO:		DDU-1436D		
UNIT :mm	SCALE:1:1			
REV:	A	PAGE:1/1		