

ROHS

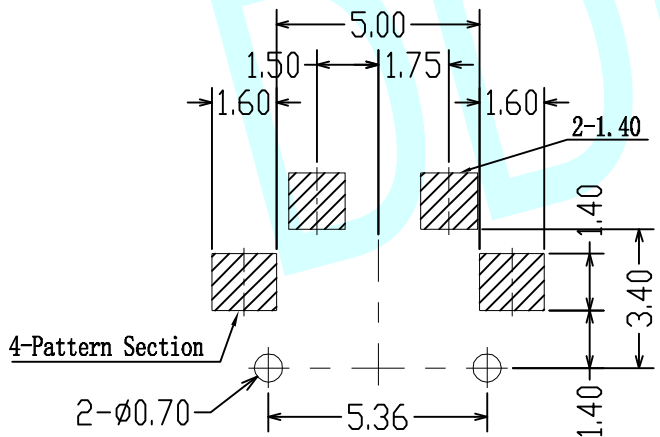

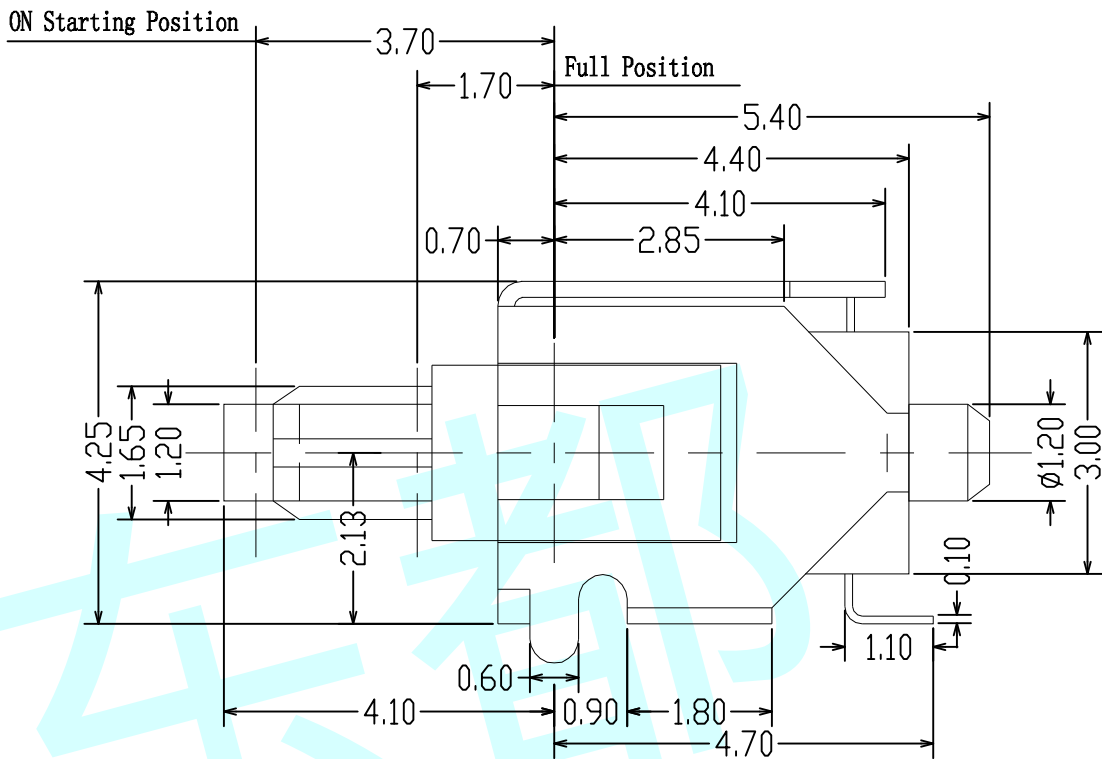

PCB Layout (Pattern Side)
Scale: 1:2

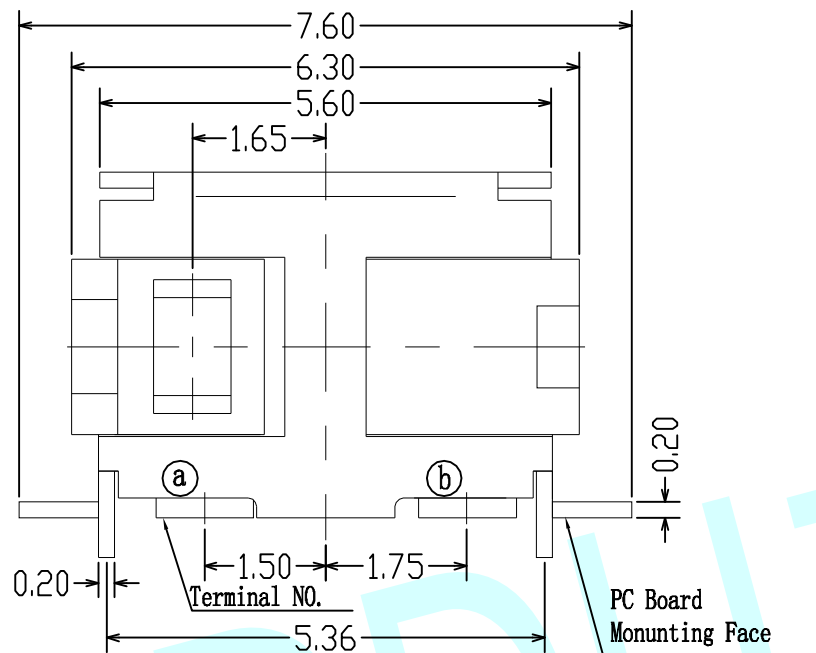
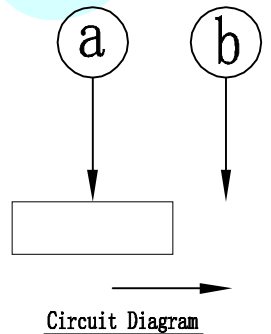

Circuit Diagram

NOTES:

1. Rating :DC 5V 0.1A
2. Operating Force:30±10gf
3. Life time :50,000 Cycles

APPROVALS		DATE	http://www.dongdudz.com	
DRAW:	ZRD	2017-12-6	TOLERANCE:	ANGLE:
CHECKED:	***	****	30≥ ±0.30	±2°
APPOVALS:	***	****	10°30 ±0.20	
			5°10 ±0.15	
			≤5 ±0.10	
 ® 东都电子 DONGDU ELECTRONICS		MODEL:	DETECTOR SWITCHS	
		PART NO:	DDU-1611	
		UNIT :mm	SCALE: 1:1	
		REV:	A	PAGE: 1/2