

ROHS

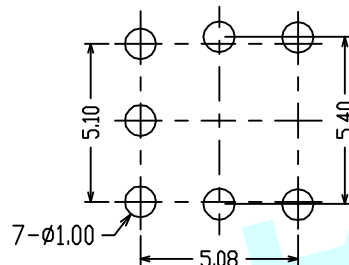

PCB Layout (Pattern Side)

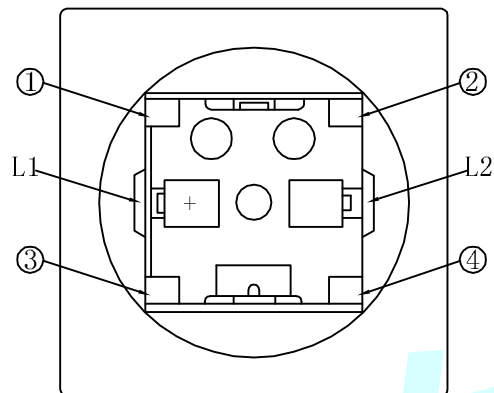

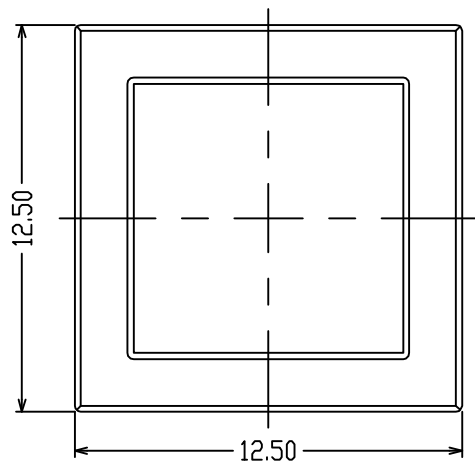
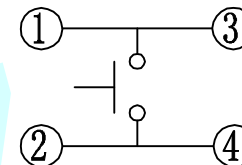

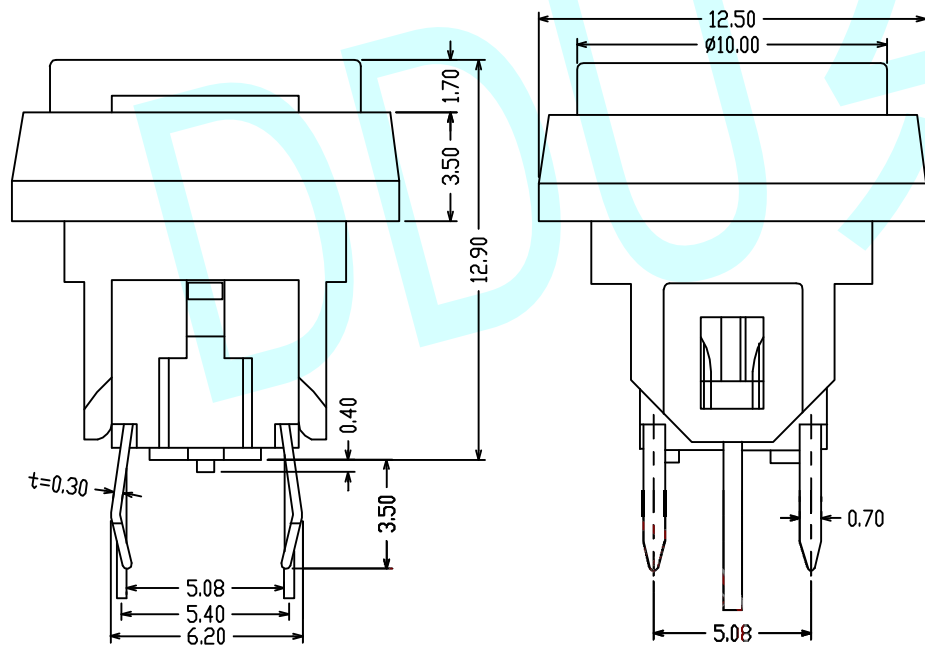
Circuit Diagram



NOTES:

1. Rating: 12V DC 50mA
2. Contact Resistance: 100mΩ Max
3. Insulation resistance: 100MΩ Min
4. Dielectric Strength: 250V AC (50/60HZ) FOR 1Min
5. Life test: 100,000 Cycles
6. Operating temperature range: -20°C ~ +70°C
7. Operation Force: 160 ± 50g / 250 ± 50g
8. Travel: 0.25 ± 0.1mm

LED Colour (LED颜色)		Whiler (白色)	Red (红色)	Blue (蓝色)	Green (绿色)
APPROVALS		DATE	http://www.dongdudz.com		
DRAW:	ZRD	2017-12-6	TOLERANCE:	ANGLE:	
CHECKED:	***	****	30°	±0.30	±2°
APPOVALS:	***	****	10°30	±0.20	
			5°10	±0.15	
			≤5	±0.10	
MODBL:		LED Tact Switch		 东都电子 DONGDU ELECTRONICS	
PART NO:		DDU-1504			
UNIT : mm		SCALE: 1:1			
REV:		A		PAGE: 1/1	