

ROHS

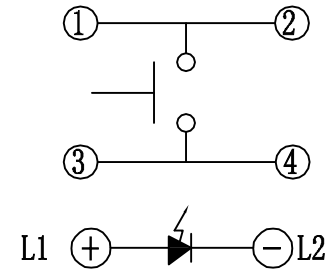

Circuit Diagram

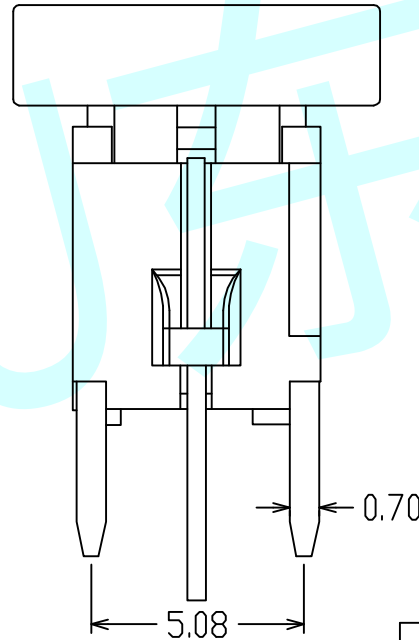
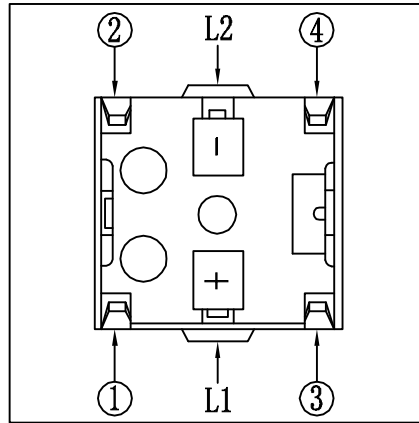
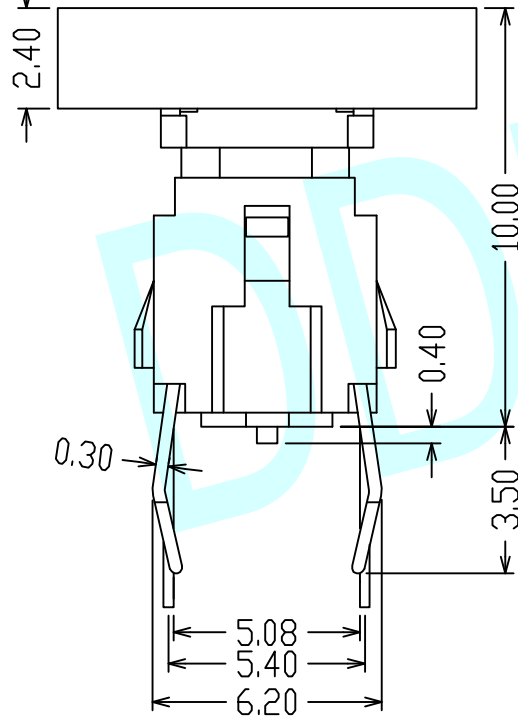
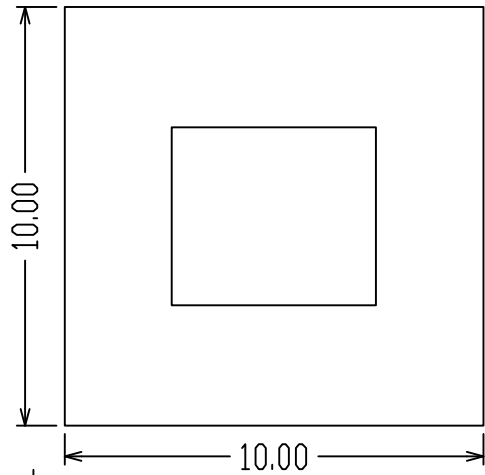
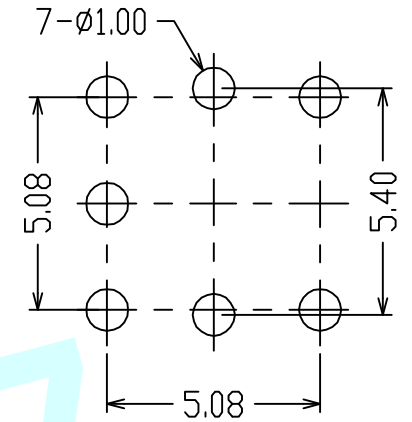

PCB Layout (Pattern Side)

NOTES:

1. Rating: 12V DC 50mA
2. Contact Resistance: 100mΩ Max
3. Insulation Resistance: 100MΩ 250V DC FOR 1MIN
4. Dielectric Strength: 250V AC (50/60Hz) FOR 1MIN
5. Life Test: 100,000 Cycles
6. Operation Force: 500gf, 1min
7. Travel: 0.25 ± 0.10mm
8. Operating temperature range: -20°C ~ +70°C

APPROVALS		DATE	http://www.dongdudz.com		LED Colour (LED颜色)	Whiler (白色)	Red (红色)	Blue (蓝色)	Green (绿色)
DRAW:	ZRD	2017-12-6	TOLERANCE:		 <b>东都电子</b> DONGDU ELECTRONICS				
CHECKED:	***	****	30 ≥	±0.30					
APPOVALS:	***	****	10°~30	±0.20					
			5°~10	±0.15					
			≤5	±0.10	ANGLE:		±2°		
					UNIT: mm	SCALE: 1:1			
					REV:	A	PAGE: 1/1		



MODEL:	LED Tact Switch
PART NO:	DDU-6148
UNIT: mm	SCALE: 1:1
REV:	A