

ROHS

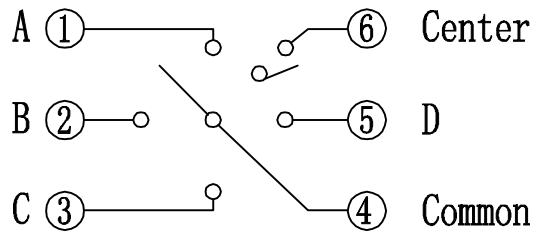

Circuit Diagram

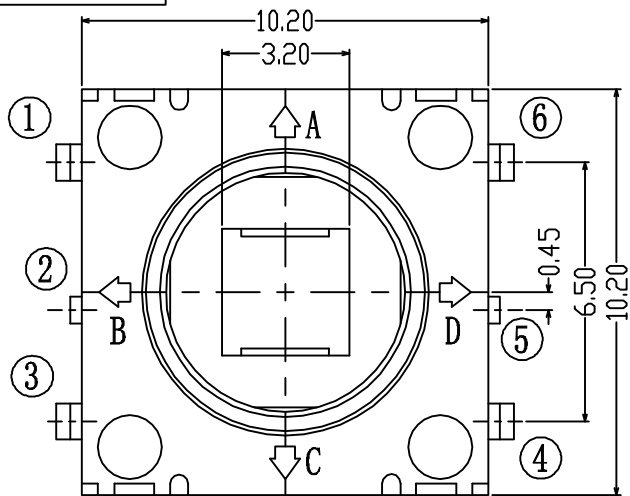
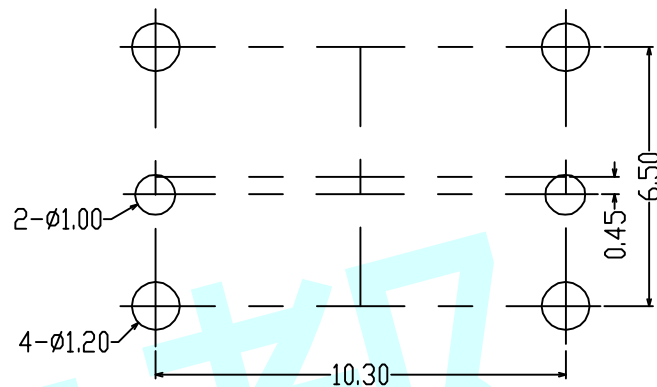

PCB Layout (Pattern Side)

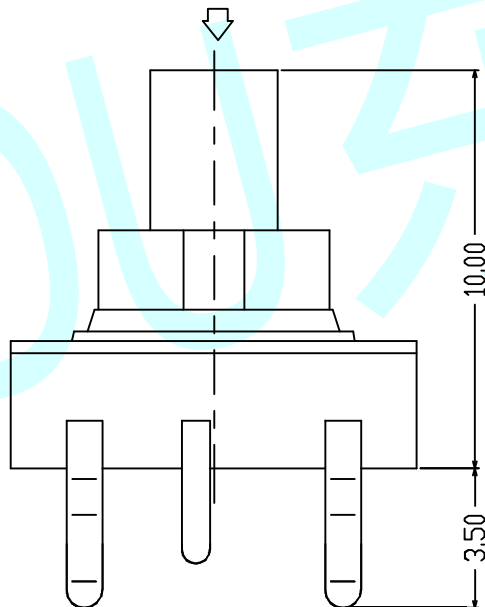
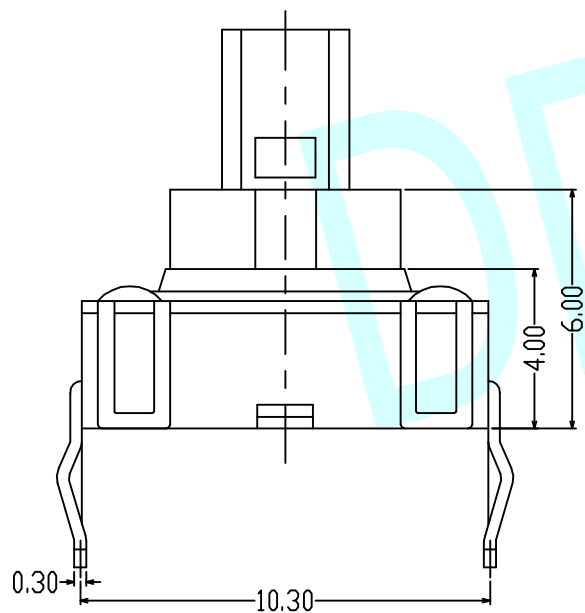

Push



NOTES:

1. Rating: DC 12V 50mA
2. Contact resistance: 100mΩ MAX
3. Insulation resistance: 100MΩ MIN
4. Service life: 100,000 cycles
5. Operating temperature: -25 °C ~ +85 °C
6. Using humidity: ≤85% RH
7. Operating Force :
 - a. 4-DIRECTION 160±35gf
 - b. Center Push 300±35gf
 - c. Travel : 4-Direction 5° ±2°
 - d. Center Push 0.20±0.10mm

APPROVALS		DATE	http://www.dongdudz.com	
DRAW:	ZRD	2017-12-6	TOLERANCE:	ANGLE:
CHECKED:	***	****	30≥	±0.30
APPOVALS:	***	****	10°30	±0.20
			5°10	±0.15
			≤5	±0.10
			±2°	

 ® 东都电子 DONGDU ELECTRONICS		MODEL:	ROCKER SWITCH
		PART NO:	DDU-1220
UNIT : mm	SCALE: 1:1		
REV:	A		