

ROHS

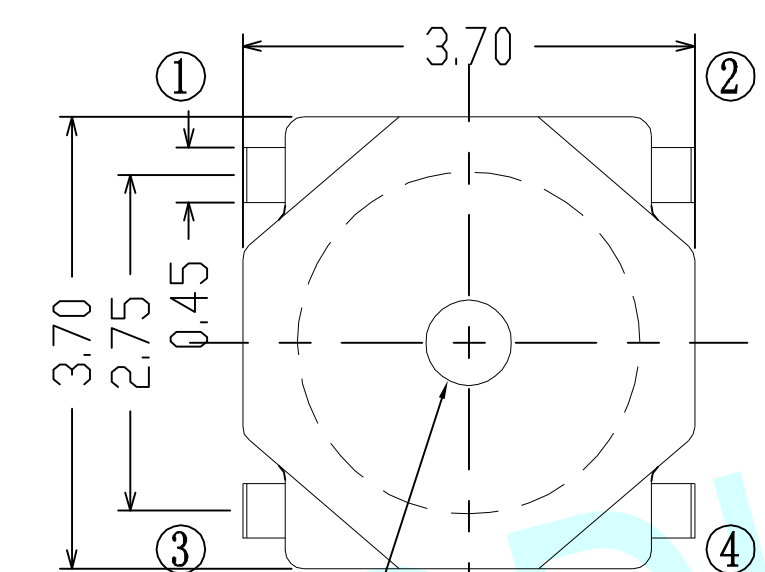

∅0.70 (Operating Position)

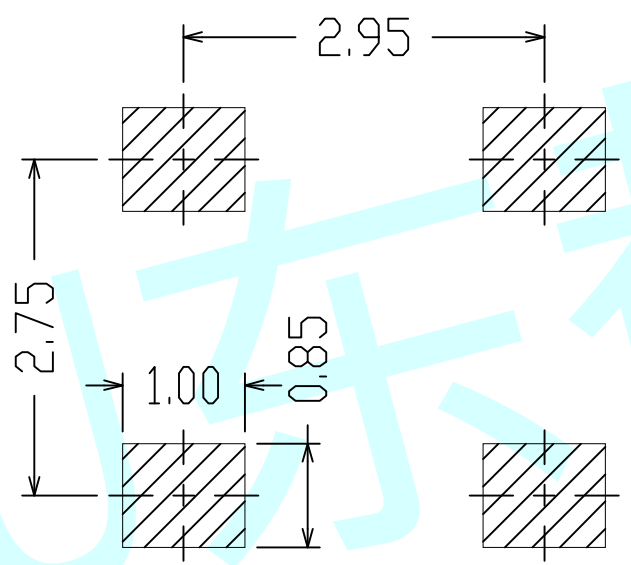
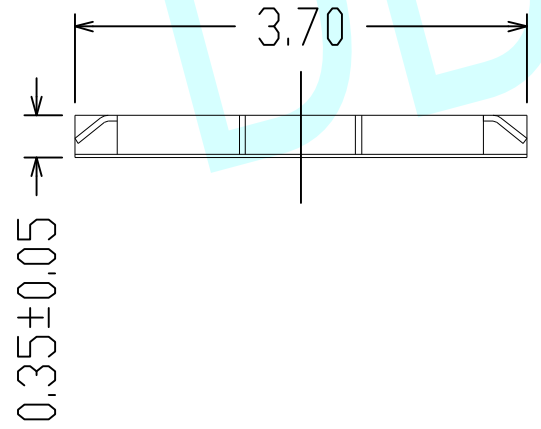

PCB LAYOUT

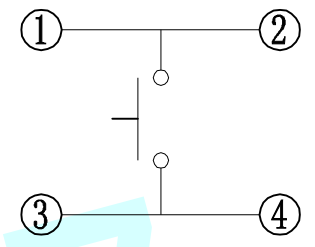

Circuit Diagram

NOTES :

- 1. Rating :DC 12V 50mA.
- 2. Contact resistance: ≤100mΩ
- 3. Insulation resistance: ≥100MΩ
- 4. Travel: 0.15±0.05mm
- 5. Life :100,000 Cycles

Stergth	90±30	130±30	180±30	250±30	350±50
---------	-------	--------	--------	--------	--------

APPROVALS		DATE	http://www.dongdudz.com		
DRAW:	ZRD	2017-12-6	TOLERANCE:		ANGLE:
CHECKED:	***	****	30° ≥	±0.30	±2°
APPOVALS:	***	****	10°~30	±0.20	
			5°~10	±0.15	
			≤5	±0.10	

 **® 东都电子**
DONGDU ELECTRONICS

MODEL:	TACT SWITCHES	
PART NO:	DDU-1148	
UNIT :mm	SCALE:1:1	
REV:	A	PAGE:1/1