

ROHS

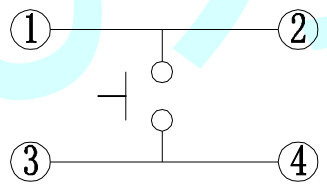

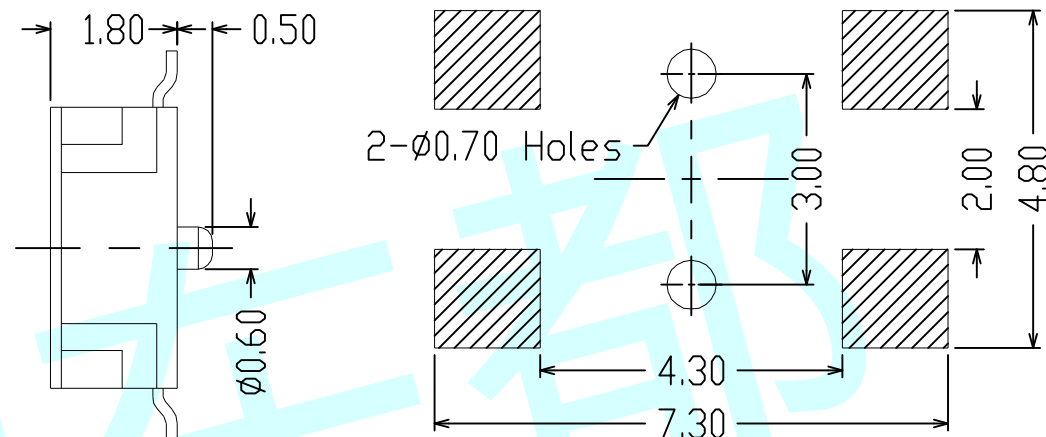
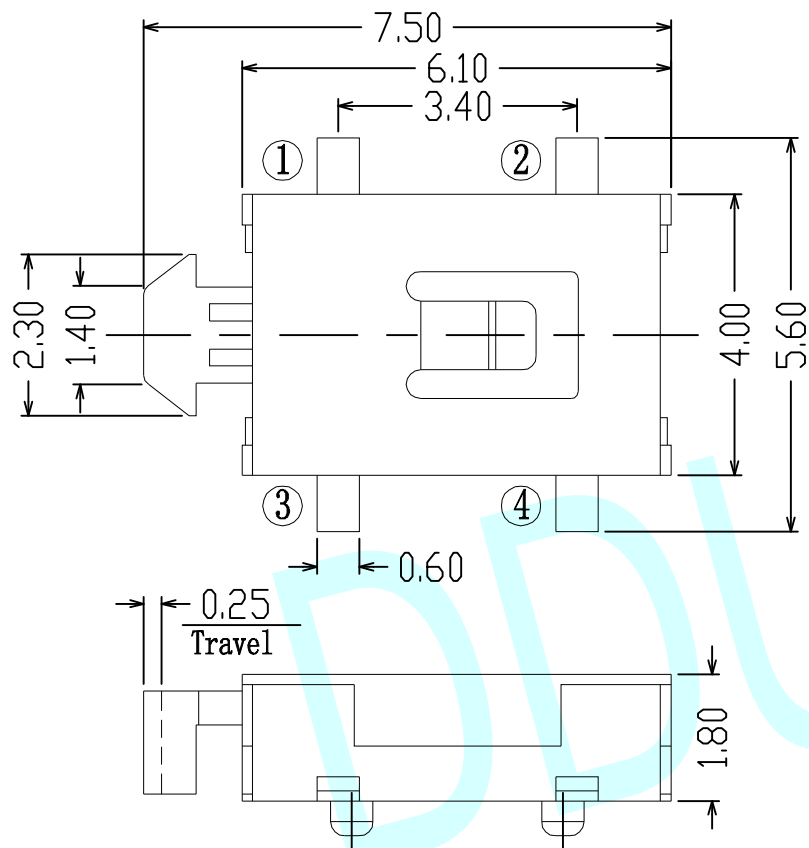

Circuit Diagram

NOTES:

1. Rate voltage. current: 50mA DC 12V
2. Contact resistance:  $\leq 100m\Omega$
3. Travel:  $0.25 \pm 0.10mm$
4. Insulated resistance:  $\geq 100M\Omega$
5. Dielectric strength:  $\geq 250V AC/1min$
6. Endurance: 100, 000 cycles

Stergth	90±30	130±30	180±30	250±30
---------	-------	--------	--------	--------

APPROVALS		DATE	http://www.dongdudz.com	
DRAW:	ZRD	2017-12-6	TOLERANCE:	ANGLE:
CHECKED:	***	****	30° ≥ ±0.30	±2°
APPOVALS:	***	****	10°~30 ±0.20	
			5°~10 ±0.15	
			≤5 ±0.10	
		 东都电子 DONGDU ELECTRONICS		
		MODEL:	TACT SWITCHES	
		PART NO:	DDU-1176	
		UNIT :mm	SCALE: 1:1	
		REV:	A	PAGE: 1/1