

ROHS

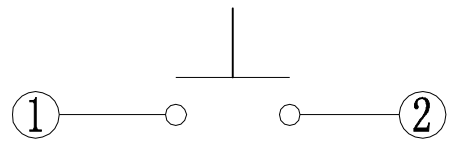

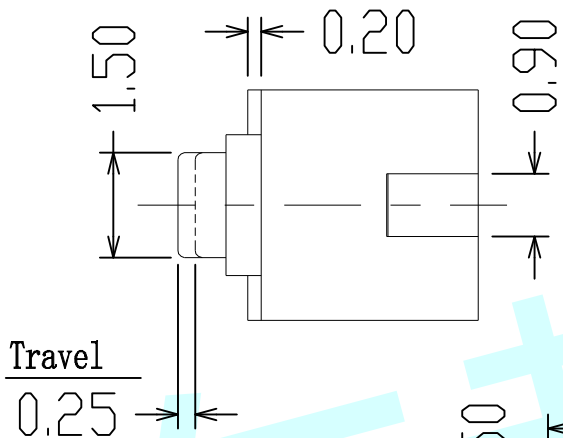

Circuit Diagram

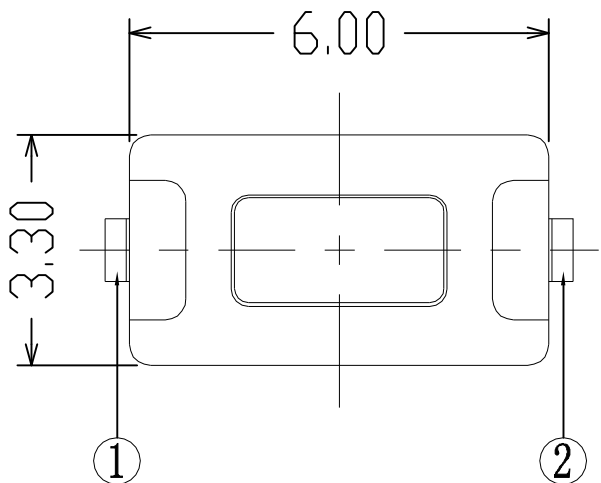
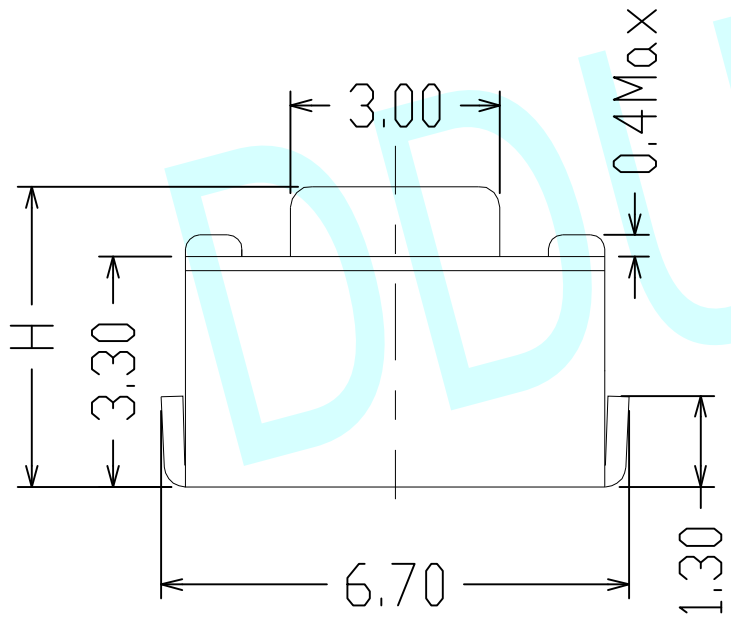

PCB Layout (Pattern Side)

- NOTES:
1. Rate voltage. current: 50mA DC 12V
 2. Contact resistance: $\leq 100m\Omega$
 3. Travel: $0.25 \pm 0.10mm$
 4. Insulated resistance: $\geq 100M\Omega$
 5. Dielectric strength: $\geq 250V AC/1min$
 6. Endurance: 100, 000 cycles

	H	4.30	5.00
Stergth	90±30	130±30	180±30
	250±30	350±50	

APPROVALS		DATE	http://www.dongdudz.com		 ® 东都电子 DONGDU ELECTRONICS
DRAW:	ZRD	2017-12-6	TOLERANCE:	ANGLE:	
CHECKED:	***	****	30° ≥ ±0.30	±2°	
APPOVALS:	***	****	10°~30 ±0.20		
			5°~10 ±0.15		
			≤5 ±0.10		MODEL: TACT SWITCHES PART NO: DDU-2025 UNIT :mm SCALE:1:1  REV: A PAGE:1/1